



---

# AM RADIO TRANSMISSION

---

6.101 Final Project



TIMI OMTUNDE  
SPRING 2020

## Table of Contents

- 1. Abstract**
- 2. Introduction**
- 3. Goals**
  - a. Base
  - b. Expected
  - c. Stretch
- 4. Block Diagram**
- 5. Schematic**
- 6. PCB Layout**
- 7. Design and Overview**
- 8. Subsystem Overview**
  - a. Transmitter
    - i. Oscillator
    - ii. Modulator
    - iii. RF Amplifier
    - iv. Antenna
  - b. Receiver
  - c. Battery Charger
- 9. Testing and Debugging**
- 10. Challenges and Improvements**
- 11. Conclusion**
- 12. Acknowledgments**
- 13. Appendix**

## **AM Radio Transmission Abstract**

Amplitude modulation (AM) radio transmissions are commonly used in commercial and private applications, where the aim is to broadcast to an audience - communications of any type, whether it be someone speaking, Morse code, or even ambient noise. In AM radio frequencies (RF) transmissions, the amplitude of the wave is modulated and encoded with the transmitted sound, while the frequency is kept the same. Furthermore, AM radio transmissions can occur on different frequencies, with broadcasts of the same frequency interfering with each other. Therefore, it is important to select a unique – or as unique as possible – frequency band in order to transmit clean, interference free, communications. And currently, many 1-way and 2-way radios, with transmission ability have some digital component in order to improve different aspects of the radio. Thus, for my 6.101 final project, I have built a fully analog circuit, in keeping with the theme of the class, that can be used to broadcast to specific AM frequencies. Thus, the goal is to broadcast as far as possible while minimizing the power consumed. Moreover, I have been able to receive these AM transmissions through an existing receiver and a receiver I built alongside this project. Yet, I have run into difficulties when extending the reception range as it arises from the antenna length, the RF transmission power, and the number of transistor stages. Moreover, I expected noise to be an issue when tested outside of the virtual environment, since the message is encoded in the amplitude and any type of noise will distort the amplitude.

## **Introduction**

For my 6.101 final project, I endeavored to build an AM transmitter. Furthermore, since time permitted, I also constructed a matching AM receiver, in order to put together a walkie-talkie and test the transmitter. For this project, I directly built the oscillator, charging circuit, and amplifiers as my main design challenges. As for the other design options, I plan to use standard BJT designs for my modulator and buffers. The inspiration behind my project comes from my previous two internships, in which I dealt with serial communication. In both cases, I was using radio technology to communicate digital information. However, in this project, I wanted to get a deeper intuitive sense of how the technology that I had been building protocols around worked. Whereas, the radio technologies that I previously used relied on various modulation transmission schemes, I used a pure AM transmission scheme due to the low frequencies that it is transmitted over. With the AM transmission scheme I will be able communicate over distance with vocals, Morse code, and more. AM transmission will also be an interesting topic to delve into because AM signals are falling out of favor and are no longer being used. Leading me to hypothesize, I may not encounter AM signals in a professional or school setting again due to increased reliability and prevalence of frequency modulation (FM) transmissions.

## Goals

### **Commitment:**

The minimum commitment for my 6.101 project was a device capable of transmitting a single frequency Amplitude Modulated (AM) signal with a minimum of a 50mW output at the RF amplifier stage. Additionally, the device is usable with a standard 9-volt battery that can be bought at most stores. With these requirements, my project uses a crystal frequency oscillator to transmit an AM signal with or without a shortened antenna on a power source of a standard non-rechargeable battery.

- Find a suitable crystal oscillator
- Design and simulate the buffer for the crystal oscillator in LTspice
- Simulated 1MHz frequency output from the Oscillator
- Simulate modulator stage with the crystal oscillator and buffer
- Simulate the RF output stage on by itself
- RF output stage wattage of 50mW

### **Expectation:**

My expectation for this project was to have a tunable AM transmitter for the range of 535 – 1705kHz that can obtain a minimum of a 100mW output at the RF amplifier stage. Additionally, to alleviate some of the power constraints, I planned to utilize a rechargeable battery with an on/off switch in order to charge the device on the go as well as turning it on and off. The charger circuit also needed a voltage doubler to increase the 5V, from the USB, to the 9V required by the battery.

- Simulated 1MHz frequency output from the Oscillator
- Simulate the tuning of the Oscillator from 535 – 1705kHz
- Simulating the entire transmitter circuit from 535 – 1705kHz
- Finding a suitable USB rechargeable battery IC circuit online
- RF output stage wattage of 100mW
- Use a voltage doubler to increase the 5V to 9V

**Stretch:**

The final goal of this project was to build a user friendly device that utilizing numerous techniques learned in and out of 6.101.

- Designing and simulating a USB charger circuit with a 9V output
- RF output stage wattage of 150mW
- Matching AM receiver circuit
  - 510 – 1705kHz bandwidth
- Simulating the AM receiver circuit
- Include on the PCB the transmitter and either the receiver or the charger
  - Use a switch to toggle between transmitter and receiver
- Using an amplifier circuit in order to play music or use different microphones

**Block Diagram**

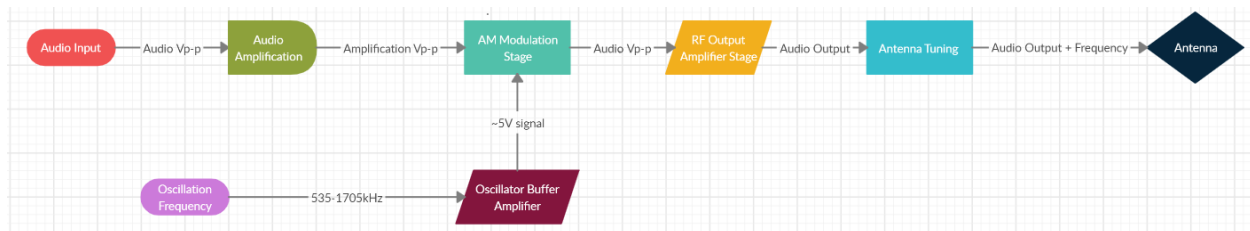

### Schematic

### Overview:

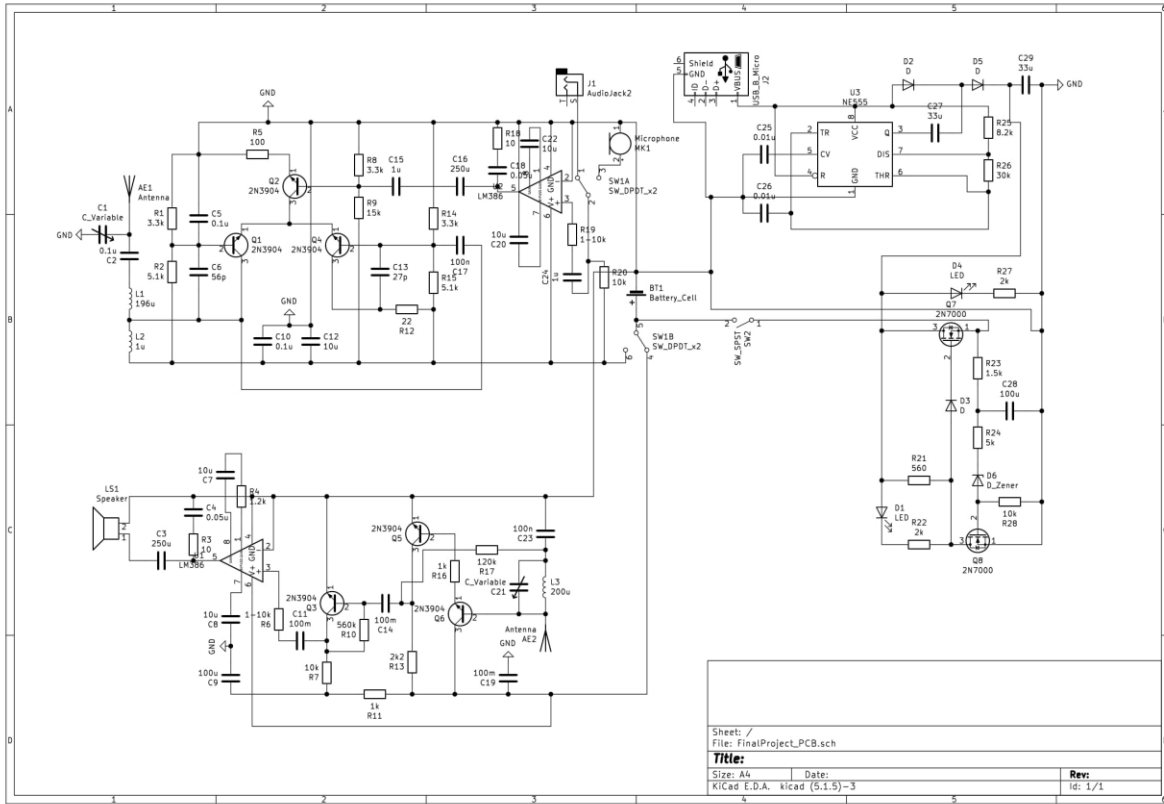

Figure 1: Schematic Overview

Transmitter:

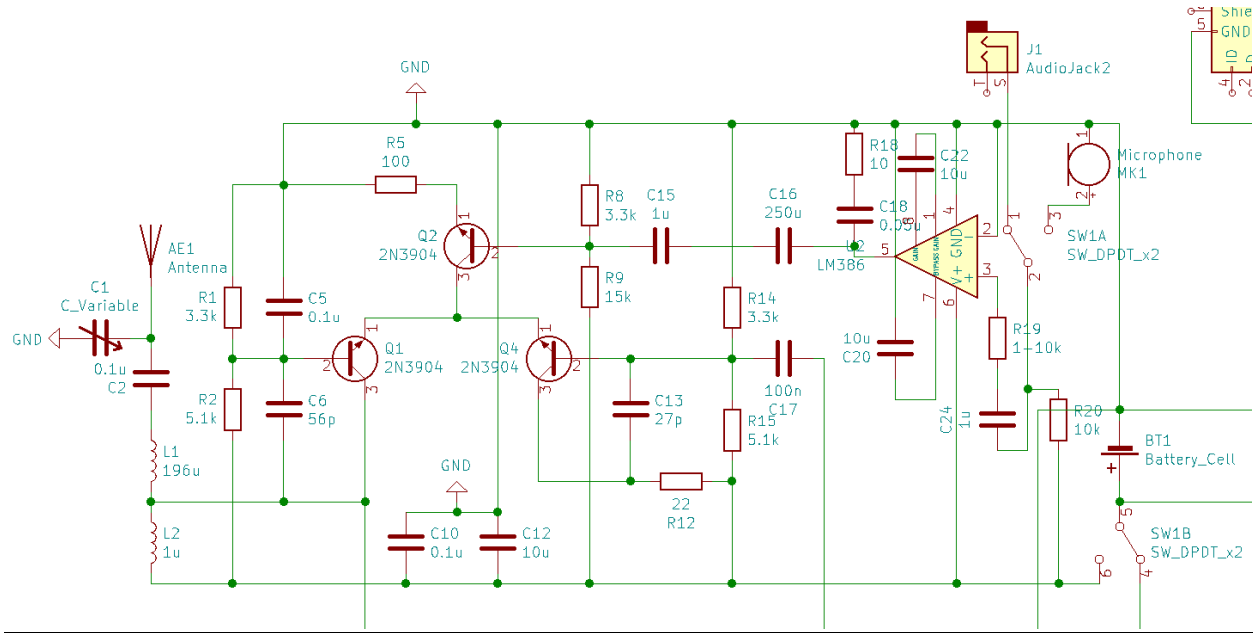

Figure 2: Transmitter Schematic

Receiver:

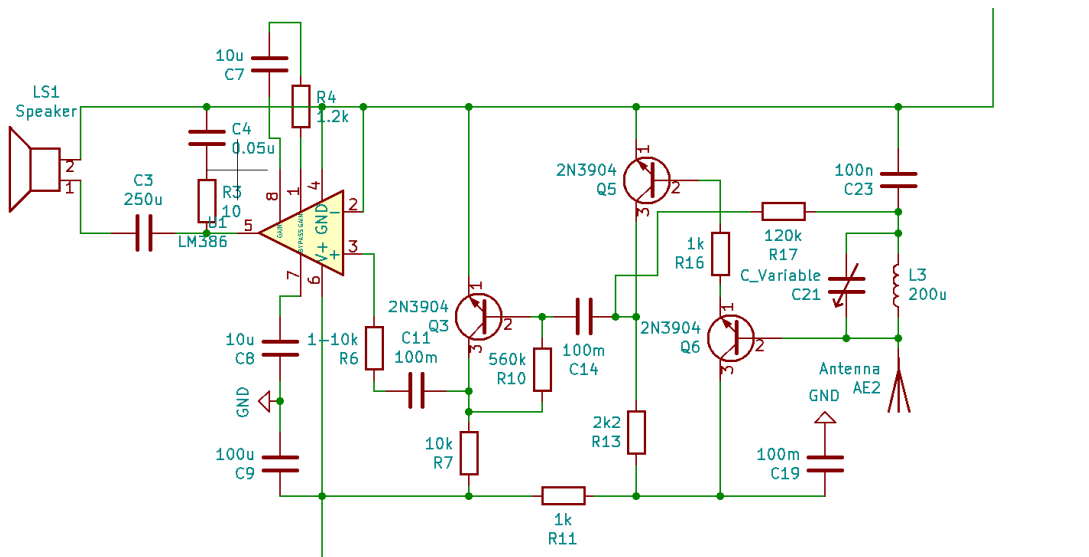

Figure 3: Receiver Schematic





## PCB Layout

Layout:

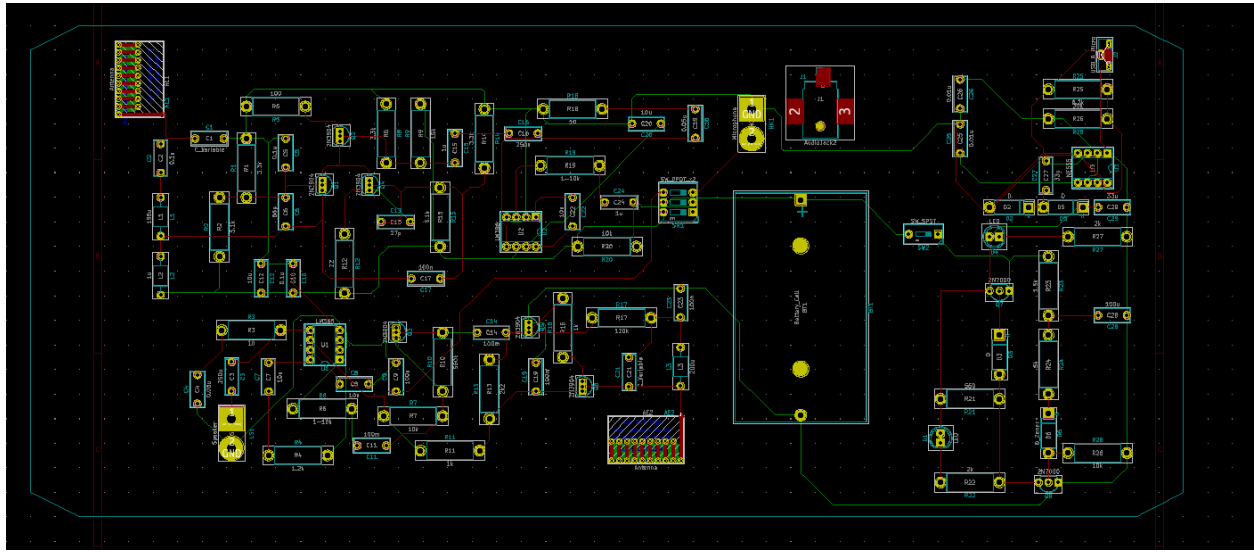

Figure 5: Entire PCB Layout

3D Front View:

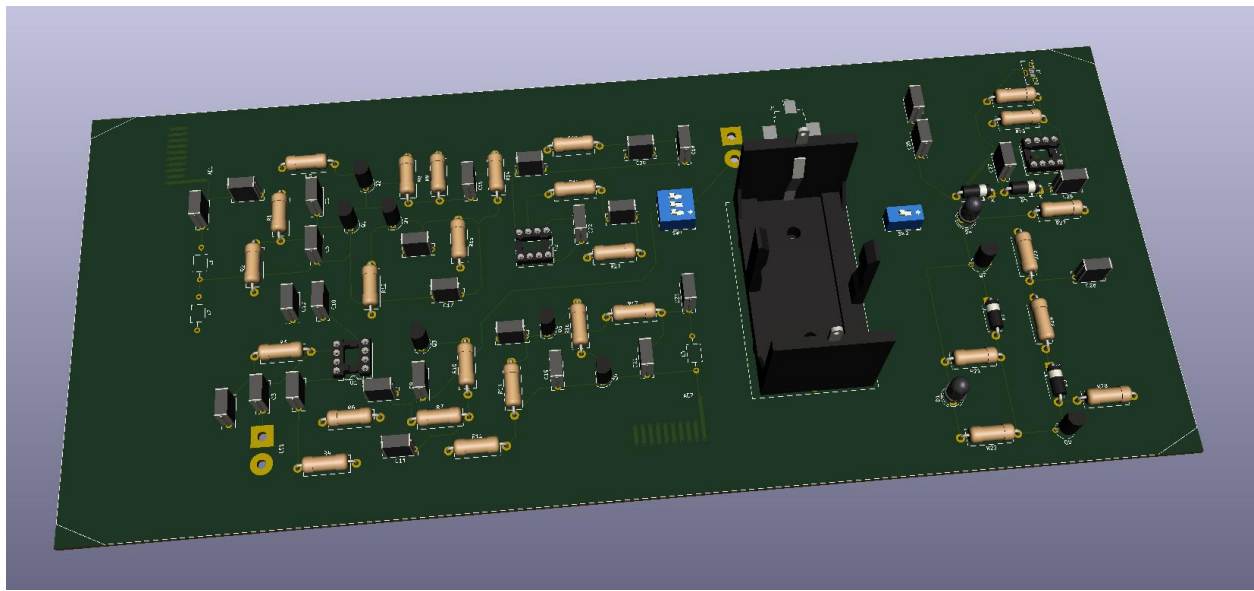

Figure 6: PCB Front Layout

3D Back View:

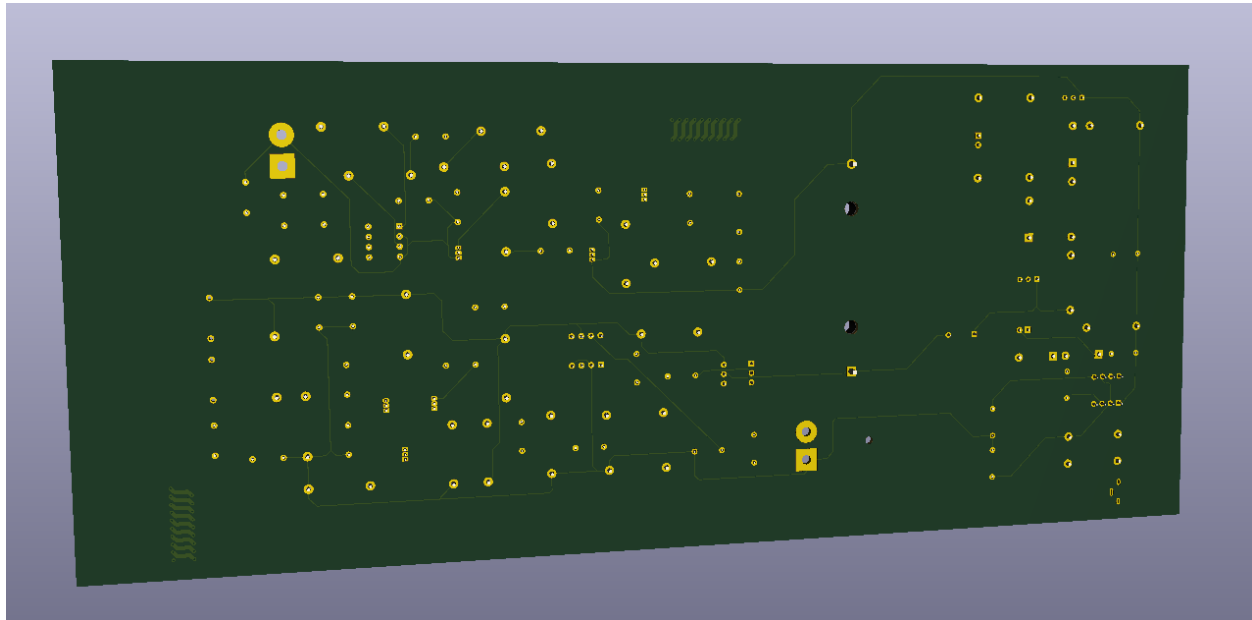

Figure 7: PCB Back Layout

### Design and Overview

The design for my transmitter is simple. I use three transistors and an oscillator as the base. The first stage modulates the incoming sound, the second stage acts a buffer for the oscillator, and the third stage amplifies the signal into the antenna. The antenna is LC circuit that feeds into both the antenna and the oscillator buffer. In this way, I only need to tune one capacitor or inductor to tune the antenna and the circuit. From these essentials, many other aspects can be incorporated into the design so that you could use multiple audio sources, a longer antenna, or more transistor stages.

When I first looked at two-way radios, the transmitter and receiver were embedded inside of each other. At first, this was the way that I also wanted to achieve my project. However, I quickly realized an intermingled transmitter and receiver were indicative of superior knowledge of how both circuits worked. Yet, I also realized that it would be better to separate the two systems for testing and debugging as well presenting my final project to others, especially at the final checkoff meeting. Moreover, when going into the project, it is important to note that we had less time than we traditionally would have. So it was important to fix into stone what and how I wanted to achieve my project.

Furthermore, in the design, I also aimed to achieve low power consumption – or as low as I could drive the power down. In my final implementation, I was able to achieve a total system power consumption of ~2.15 watts with the ~1.44 watts being consumed at the antenna. Outside of the antenna, the primary power consumers were the three transistor stages consuming a total of 0.5826 watts.

## **Subsystem Overview**

### **Transmitter**

The transmitter required the majority of my project time as it was the main commitment of the project. The transmitter – like most AM and FM radios – can be broken down into four main sections: the oscillator, the modulator, the RF amplifier, and the antenna. In the following sections, I will break down why, how, and what of the section. Why the block is necessary; How the block works, and what you need to do and have to make it operational.

### **Oscillator:**

The oscillator, in my opinion, is one of the most important pieces of a transmitter. Moreover, it allows communication of different frequencies – effectively modifying who can and cannot listen to you. Consequently, the oscillator provided the most difficulty in getting the device to work properly in part because oscillators need ambient noise to kickstart them. That means you need to program noise into LTspice and the oscillator.

Moving forward, my oscillator works through a combination of two inductors and one capacitor in order to create an oscillating signal. The frequency at which the signal oscillates depends upon the values of the inductor and capacitor. For this paper, the frequency will be given by  $f = \frac{1}{2\pi\sqrt{LC}}$  as I will be discussing tank circuits and Hartley oscillators. I do want to mention there were other oscillators such as Butler, Clapp, Colpitts, Gate, and Pierce oscillators that I considered in my circuit but ultimately decided against due to incompatibility or design preference.

In my implementations of the oscillator, I made three designs. One design using an oscillating crystal. A second design using a Hartley oscillator. And a final, third, design with an LC tank connected to both the antenna and oscillator buffer.

In the first design, I used an oscillating crystal to test that my circuit worked. It was a good way to validate that my circuit did exactly what I expected it to do.

In the second design, I applied the Hartley oscillator to the transmitter as I wanted to avoid using an oscillating crystal. The main advantage of using a custom-built oscillator was that I would be able to slide across a set frequency spectrum. The disadvantage is that the signal is not as clean as it could be as Hartley oscillators are harmonic rich devices. For my Hartley oscillator, I experimented with both a transistor and an op amp configuration. However, I ultimately settled upon an op amp configuration so that I could more directly control the gain. The main downside with an op amp is that you need to verify that its Gain-Bandwidth (GBW) product is rated above your needs and that you understand how to bias it properly. If the GBW is below your desired frequency then you will not see your output signal.

However, at some point, I realized that I could approach the problem with more tact by adding a connection between the antenna tuning circuit and the input to the oscillator buffer. With this solution, I would turn the circuit into a power oscillator and only need to tune one circuit instead of two. I was also able to see a cleaner output signal as the input was closer to a pure sine wave. Moreover, since I am about to build the device, I understand that such a large range, 510kHz – 1710kHz, may not be possible due to the large voltages involved. However, there are alternatives such as motorized capacitors or Atwater Kent capacitors that were used in old AM radios.

### Modulator:

I used a single BJT due to its simplicity. And because of that the modulator is a section is relatively straightforward. Modulators are necessary because they encode the audio input into the amplitude of the carrier frequency. You can observe the modulated signal at either the collector or emitter. To create my modulator, I used a single BJT in a common collector configuration. In this configuration, I could adjust a resistor at the emitter to control the amount of current at the collector of the amplifier BJT. I put a resistor at the emitter to adjust the current due to U.S. government regulations restricting the output power at an antenna. Furthermore, I would advise some format to control the current crossing the amplifier circuit or antenna so that you can alter the transmission distance and power. There may be restrictions for broadcasting in your area.

Once I had completed my modulator, I connected my audio input signal to the base of my BJT, with a capacitor in between to act as a filter. In my setup, the audio input controls the on and off cycles of my BJT modulator so that the signal can continue to the amplifier.

### RF Amplifier:

I used one npn BJT for my RF amplifier which still proved to be powerful in the voltages and currents that I could emit at the antenna. However, the RF amplifier can be as complicated or as simple as you would like it to be. You can even omit the amplifier, if you do not want a strong signal. For my project, I had government restrictions on how strong my antenna output power could be, so I wanted a way to limit power. I did this through my modulator, which you can observe how in the previous section. In the U.S.A., non-registered broadcasting devices must exist in the range of 510kHz – 1710kHz and not emit more than 100mW. Officially, my circuit meets all of these specifications. Unofficially, you can tweak the system to broadcast at frequencies outside of this range and at greater power. The output wattage that I intend to use my transmitter would be ~1.5W. However, I have been able to increase my transmitter above this wattage. In practice, if you want to increase the power across the amplifier, it depends upon the voltage rail, the BJTs employed, and the modulator emitter resistor.

As a last note, I would caution not to go outside of the specified range as various government functions are carried out at those frequencies. But, you can transmit for miles if desired.

### Antenna:

LTspice, does not have a built-in antenna, so I did not use an antenna. Rather, I built a band filter that would filter antenna transmissions and double as my antenna for the simulations. Furthermore, the antenna can be the simplest section of the device if you allow it. Just like the RF amplifier, you could choose to omit it. However, if omitted your transmission results just as in the RF amplifier would be seriously endangered. As both components serve to amplify the signal and boost transmission distance.

When building the antenna, I considered multiple options. I decided between including or omit a band filter and using a stub or whip antenna. Ultimately, I chose to use a band filter and a whip antenna.

For using a band filter, this gave me trouble as I needed to make sure that the bandwidth and quality factor of my antenna overlaps with the rest of the circuit. If they are different, then you make encounter a shunted signal or no signal at all. Not necessarily a bad thing, but still not ideal.

Moreover, for the physical antenna, I prefer the whip antenna for when I build the system as it will yield the best results in terms of transmission power and distance. Yet, it is less portable as it is can be long and unwieldy. This type of antenna is ideal for long-range, reliable communication. If I were to use the stub antenna, then I may be cutting my transmission power and distance by up to 30% with the bright side of having a portable radio. This antenna is ideal for short-range, easy-use communication.

In short, the choice of which, if any, type of antenna is completely up to you and your needs.

## **Receiver**

While one of my big inspirations behind the project was to craft a fully functional walkie-talkie, I did not have the required time to fully create my own receiver due to the ongoing COVID-19 situation. Thus, I resorted to pulling a bare bones AM receiver schematic online that I could tweak, improve, and present.

The receiver schematic follows a similar layout to the transmitter. In truth, it is not too much more that a transmitter in reverse. And, this makes sense – you catch with the same hand you throw. As you would not want to add more complexity than is needed

Thus, in the receiver, you will see 3 BJTs, the same number as in the transmitters. The first and second npn BJTs act as a Darlington pair buffer so that the tank circuit does not overload the rest of the circuit. Whereas the third npn BJT acts with a dual purpose. The primary and secondary purpose being to demodulate the signal and amplify the output signal, respectively. Additionally, the resistor reaching from the bottom of the tank circuit to the base of the third transistor serves to create regenerative feedback – boosting the signal in order to improve circuit reliability and performance. I set the resistor value at 120k, but if you were to use a 33k fixed resistor in series with a 100k potentiometer, then you would be able to filter the selectivity and sensitivity of the device.

## **Battery Charger**

Building the battery charging circuit proved to be one of the most interesting aspects of the project as I needed to take in the power consumption of the project and decide what supply voltage I needed to use and whether to restrict or increase current consumptions in different parts of the circuit.

I ultimately decided upon a rechargeable 9-volt battery. I chose a rechargeable battery as it would be more convenient to fuel the system on demand rather than searching for new batteries whenever I wished to use the system. Additionally, adding a rechargeable battery added an additional challenge in order to build a circuit to charge the battery.

When I decided I wanted to use a rechargeable battery, I wanted to use a 12V battery. However, the only available rechargeable 12V batteries are car batteries. So, I decided to go with a 9V battery in order to maintain portability.

The charging circuit may look somewhat intimidating, but it is surprisingly simple. The 5V input voltage is applied to the NE555 so that the output voltage is doubled to 10V. Proper biasing of the NE555 can be seen on the NE555 data sheet. It should also be noted that the NE555 is a dexterous IC chip that can act as an oscillator and numerous other functions. From the output of the NE555 chip, the new 10V is fed into the actual charging portion of the circuit. While the battery is charging one LED will be lit. when the battery is fully charged, two LEDs will be lit. This is due to two MOSFETs or SCRs acting as voltage regulated switches. That is the entire explanation for the charging circuit. Moreover, the battery can still be used while charging. Moreover, in the charging circuit there are two LEDs. One LED is lit by the USB power and the other LED is lit when the battery reaches 9 volts as it is above the Zener breakdown voltage. This second LED helps alleviate overcharging, but is not fully if the battery is charged for an extended period.

As a side note, I want to reiterate that you can use the NE555 to create a greater range of voltages. In fact, you could even take the 9V from the battery and boost the voltage to 12V or 15V in order to increase the range of the radio

## Testing and Debugging

All testing was done primarily by hand and LTspice. After testing, I laid out a schematic with KiCad and turned the schematic into a PCB board layout.

I approached testing in LTspice in a linear fashion. I went section by section. First, I completed the battery charging circuit as it was the most straightforward. Then, I built the three transmitter circuits. The three transmitter circuits are the exact same with the only difference being their oscillator component. Finally, I built the receiver.

For the voltage multiplier portion of the battery charger, I made two designs – both with the NE555 chip. And, I made two to see which multiplier would reach 10 volts quicker with the goal being to have a quick circuit. Below you can see the results of the two circuits in *Figure 8*. Both starting at 5 volts.

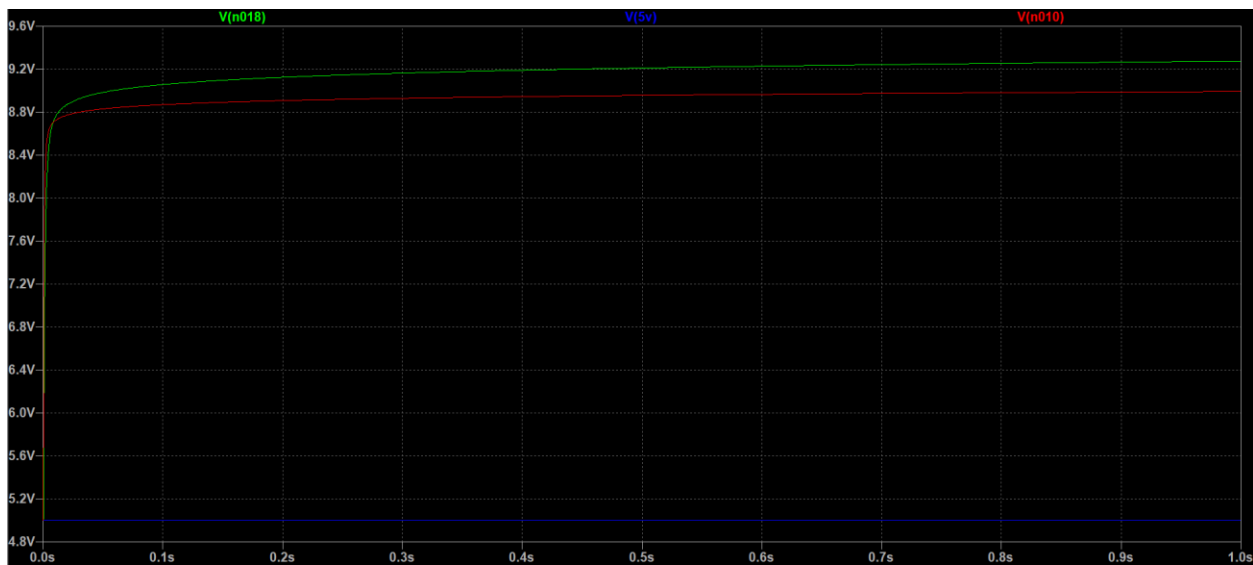

Figure 8: Battery Charger Simulation

From the voltage multiplier, the output voltage is connected to the actual charger circuit. Testing this piece of the project is not too tricky. All that needs to be done is place voltages ranging from 0V to the desired battery voltage and measure how the circuit reacts to those different voltage levels. To do this, take out the battery, and place your varying voltage connection to where the battery belongs.



When building the transmitter, I first verified that the crystal oscillator would be working,

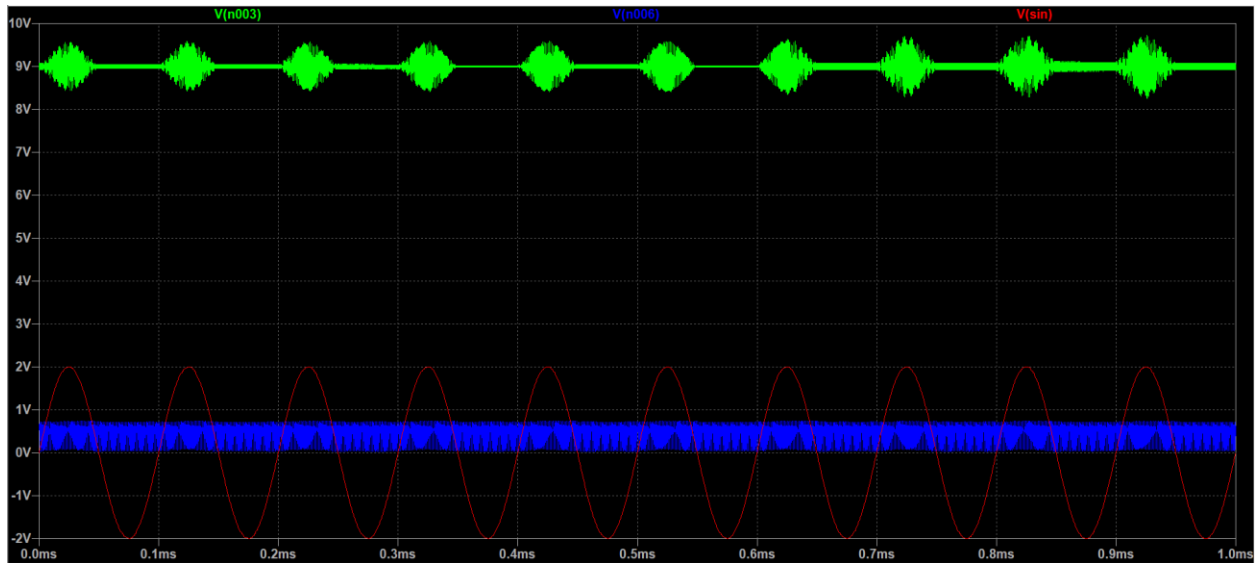

Figure 9: Poor Filtering Example 1 - Crystal

and then moved onto the Hartley oscillator portion. But what I want you notice right now is that while the signal is modulated, there are some rough edges on the back end of the signal in *Figures 9 and 10*, crystal oscillator and Hartley oscillator, respectively. This comes about due to improper antenna band filtering. And, I chose these photos specifically to display what happens when the two oscillating circuits are not in tune.

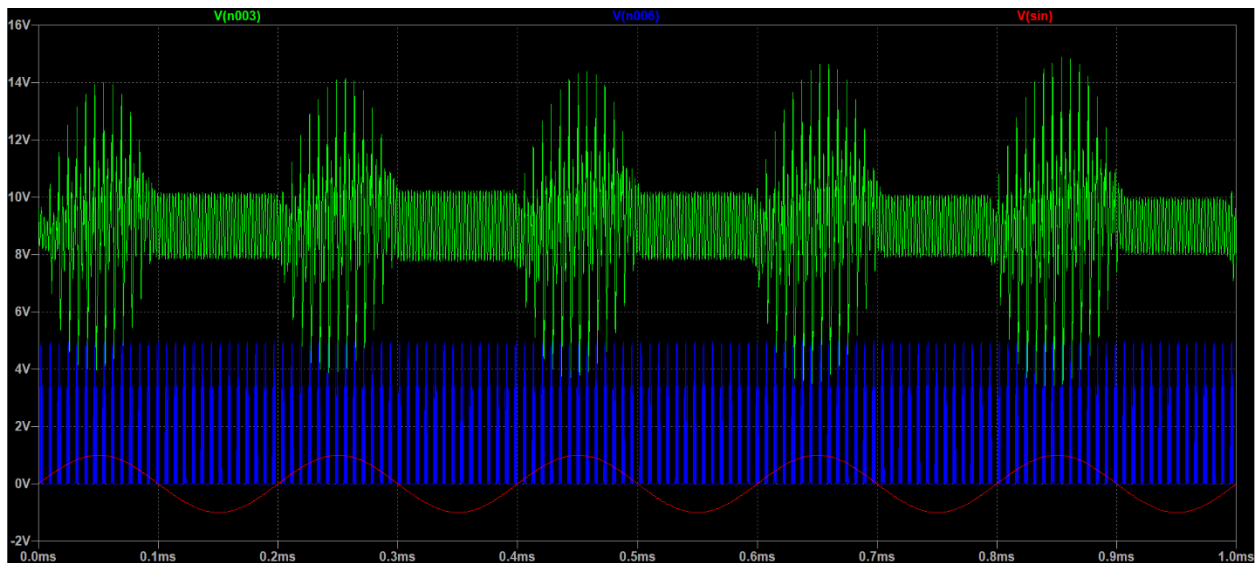
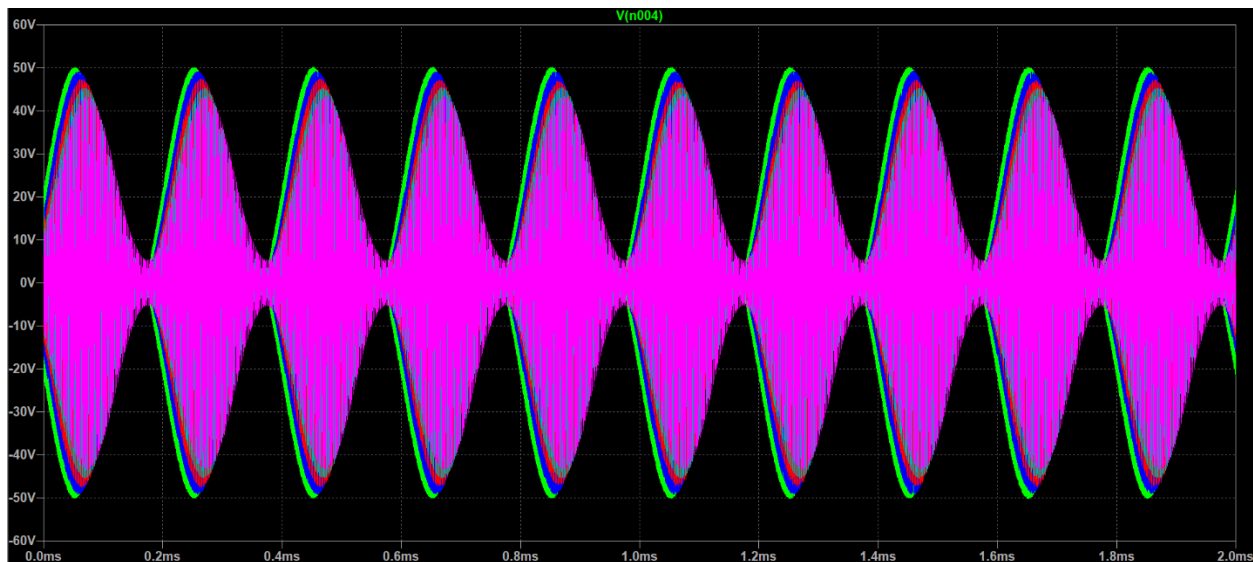

Figure 10: Poor Filtering Example 2 – Hartley Oscillator

However, in both situations, while the signal is distorted the message is still allowed to propagate. I do want to emphasize that these two signals were not my end product, but what I first encountered before correctly tuning my circuit. If you want to see my finely modulated

signal see *Figure 11*. I only included one photo of the modulated signal from the three circuits as once the signal is fully modulated, they appear identical. Furthermore, I realized more than one identical photo would be redundant. To see the functional circuits as well as the rest of the working circuits, see the **Appendix**.

Moreover, the only solution to this problem is to have the two tuning circuits match, which as I have showed is difficult to do. Yet, I was able to simplify this process by combining the two oscillators into one. Thus, turning the circuit into a power oscillator. In the image below, you will see a finely tuned circuit for the full range of 510kHz – 1710kHz.



*Figure 11: Ideal Filtering - Power Oscillator*

At one point when I was still developing the Hartley oscillator, I realized that my oscillator was not behaving properly in LTspice due to the lack of noise – oscillators need random noise in order to start oscillating. I was conflicted on how I was to navigate the situation. On one hand, I could ignore the problem as I knew the circuit would work in real life. However, on the other hand, I could try to input random noise to jump start the system. I opted to jump start the system in order to demo the Hartley oscillator. This is just to illustrate an example of how using LTspice as a sandbox can quickly become a problem if you are not intimately familiar with the nuances of theory and practicality. I would like to add that after this project, I plan to build the full system upon my return to MIT – fingers crossed for the Fall of 2020. Yet, LTspice is not full of negatives.

LTspice also helped me realize that I could fully omit the Hartley oscillator by feeding the antenna tank circuit back into the buffer npn BJT in positive feedback. When I did this the modulated circuit became much cleaner as I was not depending upon two oscillating circuits for transmission, but one. As a last note about the oscillators, I used two inductors and coupled them together. I did not initially couple the oscillators, but I eventually did as they would be coupled

in practice due to mutual inductance. Thus, the total inductance increases. Be aware of this phenomenon or use a transformer.

When testing the modulator, I ran into the trouble of inputting a square wave. While it is an easy way to increase power is to input a square wave. You will see sharp peaks due to the rapid change in voltage that the inductors will try to fight. The mistake I made was not realizing that my square wave had a 0s rise and fall time. When this was rectified, I was able to see non-lethal voltage spikes.

For the antenna, I have already highlighted the issues that involve the oscillators I encountered when building the three transmitter versions. Moreso, I still want to reiterate some of the options I had when testing and debugging. Originally, I did not think that the antenna would yield any problems. But, I was underestimating the simplicity of what I was doing. First, I want to admit that you do not necessarily need to tune an antenna. But, antenna tuning results in better transmissions signal due to the omission of excess noise. I made the mistake of thinking that it was enough to set the inductor and capacitor values to the same values. However, when you do this, you are forgetting about the bandwidth and quality value. Depending on how wide you want your transmission bandwidth, you need to be pre-meditated in what specific values you use. Furthermore, I would recommend the quality factor be wide if you want to sweep a frequency band and narrow if your device is set to one frequency. Since we are on the topic of bandwidth and quality factor, I should also mention that your oscillator will also have a bandwidth and quality factor. You want these values to be as close as possible, if not at least have a sizeable overlap territory.

Finally, I tested the receiver last – see *Figures 12 & 13* input and output signals. This was only natural as I needed to produce a modulated signal first to feed into the device. However, if you wish only to make the receiver, there is a way to simulate a modulated LTspice signal. You do this by taking two independent voltage sources – one controlling carrier frequency and the other the signal source – and multiplying them by using a dependent voltage source. From there you, you can either feed in that signal or the signal attained from your transmitter signal. Now, if you look at the output –voila – you should see your newly transferred demodulated signal. Lastly, I want to say that I included a capacitor and resistor at the output in order to help simulate a speaker. These two components are not need for a physical implementation. I would encourage you to remove them upon building.

The receiver input and output, respectively.

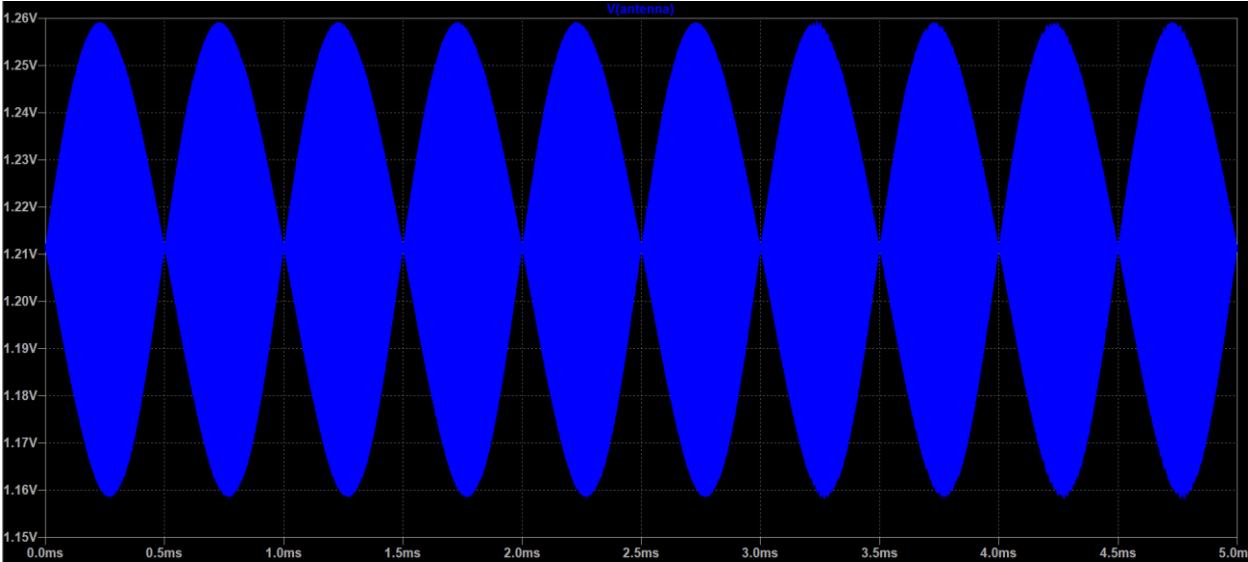

Figure 12: Receiver Input

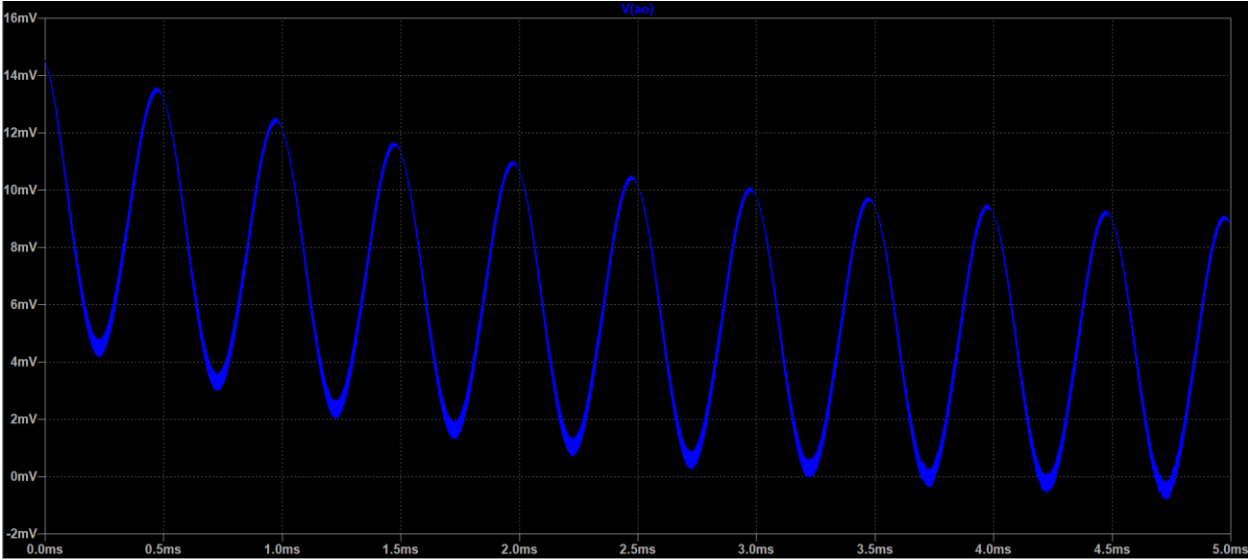

Figure 13: Receiver Output

That concludes my discussion of major hurdles in testing and debugging. While there are more minor bumps, they do not affect the reliability and performance of the end device. I have included photos of my LTspice simulations in the case you are interested in recreating my project.

## Challenges, Improvements and Reflections

For this section, I want to begin with a general discussion and then dive right into specifics. I hope my experience in the spring of 2020 is a one-off experience for this class. But, I believe that all this advice would be relatable to any student in the future.

The most important advice is to start early! I cannot emphasize this enough. Hopefully, you have picked a project that truly interests you. And, if the project does interest you, it will take more than one or two weeks to finish. Really try to utilize the full six weeks even with the presentations to fully flesh out your ideas and implementations.

Second, now that I have used LTspice extensively, I can say that nothing beats debugging by hand or a breadboard. While breadboarding has many non-idealities that you encounter. Those are the problems that you are trying to fix. When you debug through LTspice, it is not the same and not as enjoyable. You can try to program noise and other potential problems into LTspice, but those might not be all or any of the potential bumps in the road. An engineering teacher once told me there are three types of knowledge in this world: what you know you know; what you know you don't know; what you don't know that you don't know. Often, the third type of knowledge is the most dangerous as there is no way to prepare or defend against these pitfalls. Thus, while my circuit works perfectly in theory, there will most definitely be aspects that it can be found lacking.

Yet, one of the things that I liked about LTspice was how quickly you could discover the root of a problem. When you debug in real life, you cannot press a button to verify all of the wires are connected, quickly verify currents and voltages, or connect different modules. LTspice makes circuit designing easier and better when used in conjunction with building the circuit in real life. I would truly recommend LTspice as a tool to other engineers for its ease of speeding up developmental processes.

Funny enough, there was one mistake that I kept committing, not increasing the LTspice timeframe scope. This was a fix that I caught with relative ease and speed. But, I do want to emphasize that different aspects of the project run at different times so one section may take  $1\mu\text{s}$  to run whereas another section may need  $10\mu\text{s}$  to run. I spent fifteen minutes more than I needed wondering why my voltage multiplier output voltage had not increased beyond the input voltage. Consequently, I encourage you to be aware of the dichotomies in runtime.

Additionally, one of the biggest challenges that defined my project was the oscillator. However, it did not have to be the big challenge that it was. If I could go back, I would test all of the modules in the transmitter individually to my satisfaction and then combine them. With oscillators there is so much going on with them and really taking the time to understand the hard math behind them would speed your discovery exponentially.

For the battery charger, I really wanted to build my own DC-to-DC voltage doubler with a solar panel connection. Yet, I was short on time. Adding a solar panel is not too hard, but I was unable to obtain parts in a timely fashion. Furthermore, I would really recommend building your own voltage multiplier. It is an interesting topic and you could even boost the transmitter overall signal from 9V to 12V, 15V, or more as that increase would create a stronger signal.

With the receiver, I wish I had more time on this topic as it would have been neat to control the entirety of the aspects in the circuit. However, time did not allow for this. I did still create a reasonable receiver, with some help, that can drive headphones or a loudspeaker.

As you can probably tell, time was my biggest challenge. I started the day after spring break, but that goes to show time is tight.

Moreover, the one thing that I would like to improve as a whole about the circuit is the energy efficiency. This was a priority coming into the project as my device is battery powered and can only last so long. I wanted to use energy efficient parts and control the current at different stages in the circuit. While some of my circuit has energy efficient capabilities, the whole circuit does not.

## **Conclusion**

Overall, I would say that this project was a success! I really enjoyed learning the fundamentals of circuit design and how to build devices from scratch. The final implementation of these skills into the final project really illustrated to myself how much I learned over the course of the semester. Now that I have a fully operational transmitter and receiver, I might just open a radio station, who knows!

I would say for my device, I tried to incorporate as many different aspects of functionality so that anyone, interested or not, can pick up the product and use it intuitively as I do not want it to have a high learning curve.

When going into this project, I realized that I wanted to build something that would typically require at least a two-man team. So, at the advice of the teaching staff, I scaled down the commitment and expected goals to reflect what a one-man team could realistically do and orient my stretch goals for what a two-man team would be able to do. And, the plan worked well. I was able to achieve for the base and expected objectives and stretch just enough to reach the entirety of my goals.

As for parting advice to future classes, I would really encourage them to start early and pick something that truly interests them. I can only imagine how painful this project can be if

you picked a topic that you did not like to work with a friend. On the flipside of this is to pick a partner or team that you can function with and that you can rely to do their sections. It may seem ironic that I say this since I did my project alone, but I want to emphasize that I did my project alone as the class was moved online. I also did not want to run into different issues such as time zone and other potential reasons as there are not too many ways to keep people responsible over the internet.

If another student were to re-attempt this project, I would say try to work on creating an ultra-efficient receiver. One that could pick up 1mV and below signals and losslessly amplify them while getting rid of the potential noise. I say this because I was recently inspired by the deep space missions of the twentieth century, where these far away satellites would transmit signals that would be attenuated to almost insignificant level when reaching Earth. I plan to work on this after the class ends.

Finally, I want to add that I also connected an audio amplifier to both the input of the transmitter and the output of the receiver, but I was not able to include into the LTspice simulations as there was not an adequate model in the libraries. However, I was able to include the amplifier and its two different gain configurations into the PCB layout. 50 and 200 gain for the receiver and transmitter, respectively.

Lastly, I want to reiterate how grateful I am to see the class through as it showed me how an electrical engineer would go through an original design process, taking an idea from thought to a fully functional application. Innovation is not a straight path. Rather a path that turns and twists like a ravine that an engineer should be ready and excited to venture down. I would emphatically recommend 6.101 to other students.

### **Acknowledgements**

I found 6.101 to be a truly enjoyable class, and it would not have been possible without the amazing staff. Specifically, for our teaching team, Gim, Negar, and Mark who have been supportive and encouraging in person and online for this term. Additionally, I would like to acknowledge various online websites and forums that have been helpful.

## Appendix

### 1<sup>st</sup> AM Transmitter

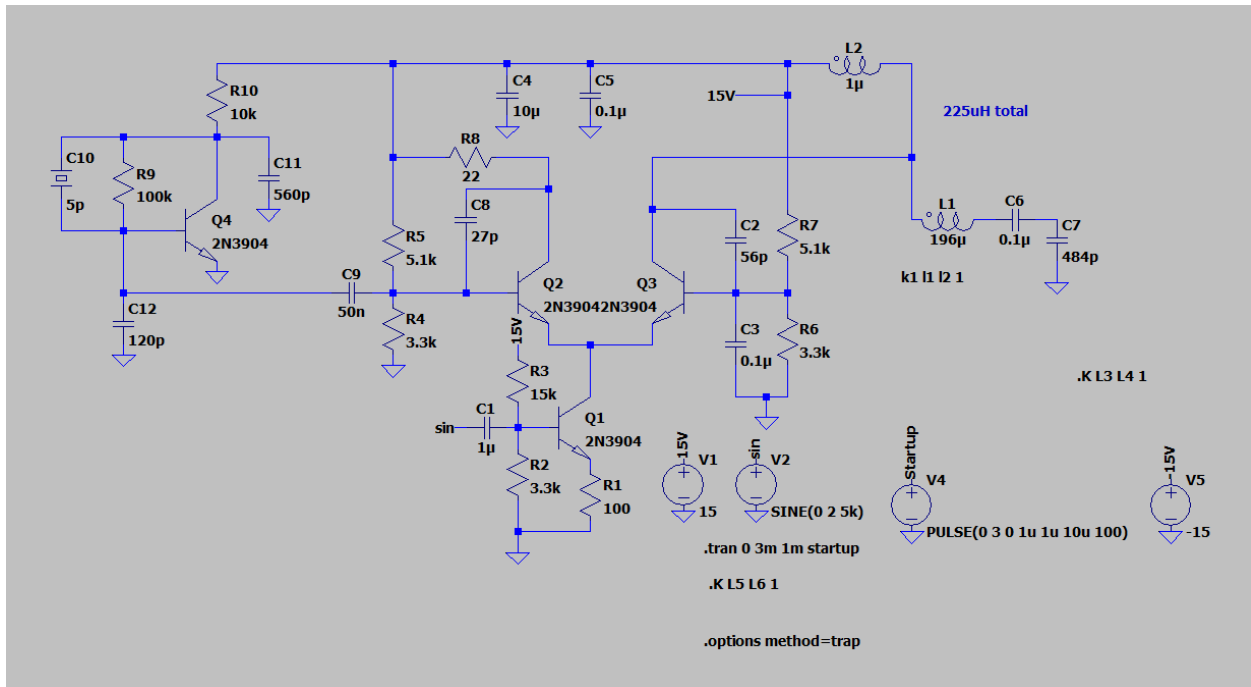

Figure 14: Crystal Oscillator

### 2<sup>nd</sup> AM Transmitter

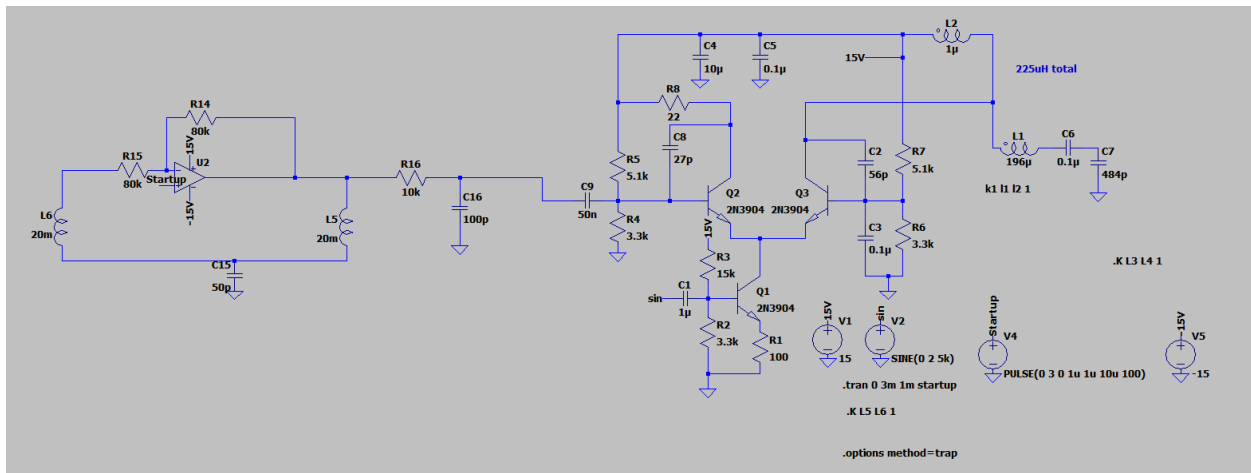

Figure 15: Hartley Oscillator



### 3<sup>rd</sup> AM Transmitter

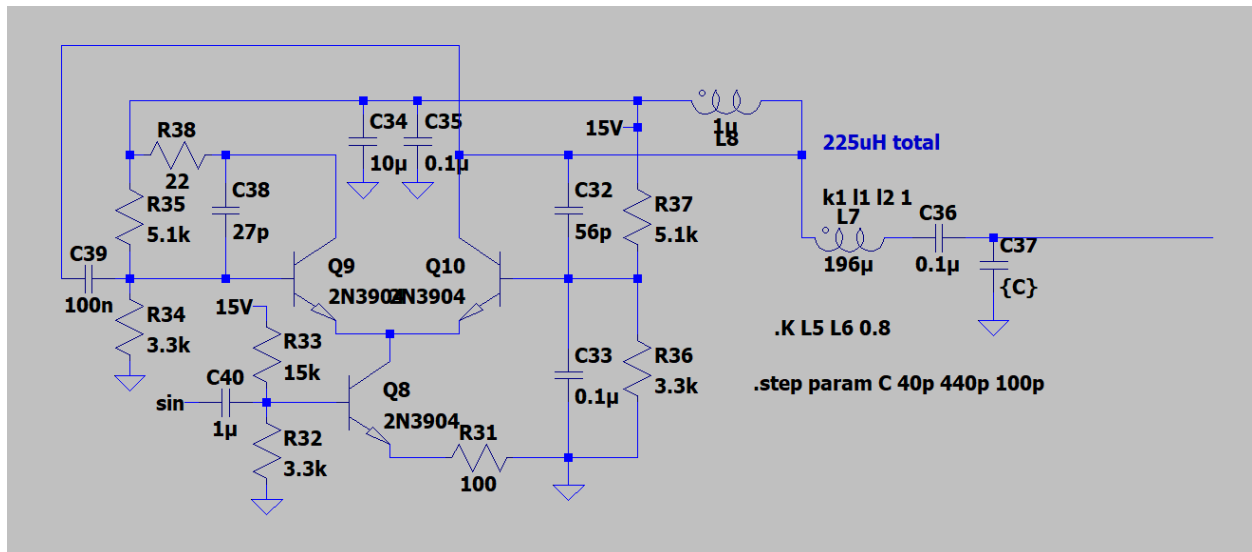

Figure 16: Power Oscillator

### AM Receiver

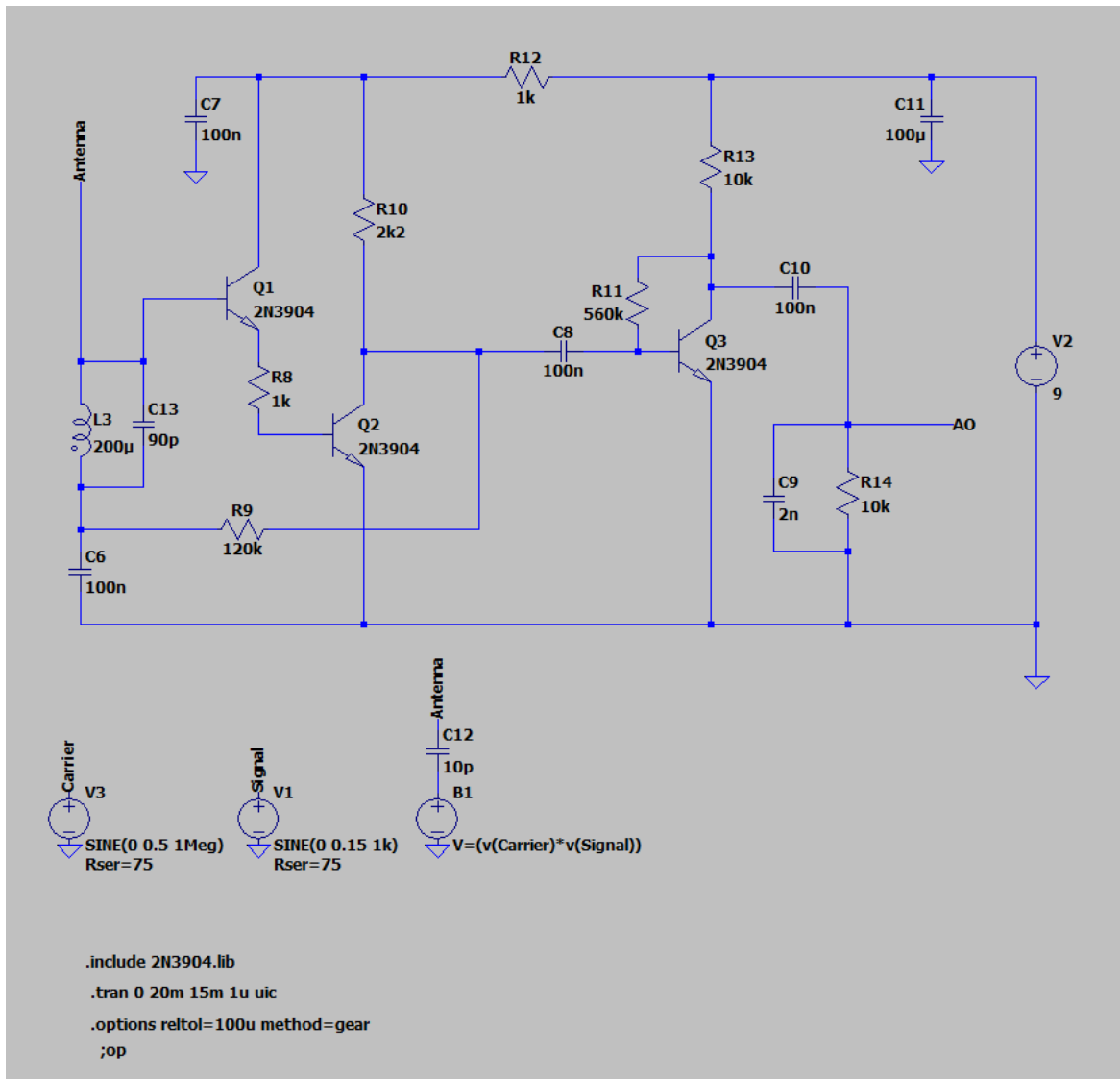

Figure 17: Receiver

### Battery Charger

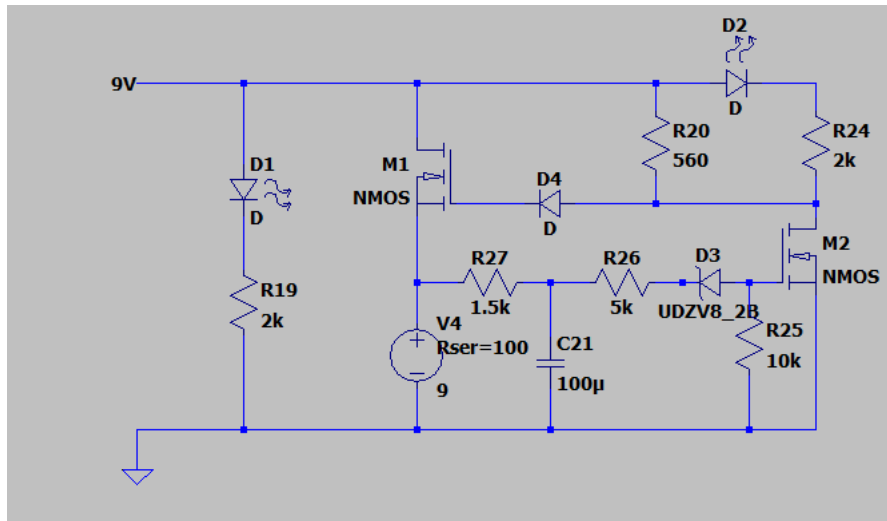

Figure 18: Battery Charger

### 1<sup>st</sup> Voltage Doubler

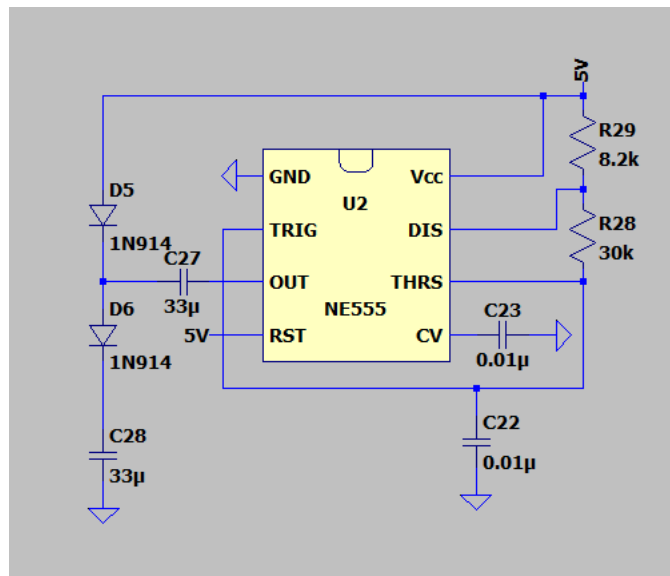

Figure 19: Voltage Doubler 1

2<sup>nd</sup> Voltage Doubler

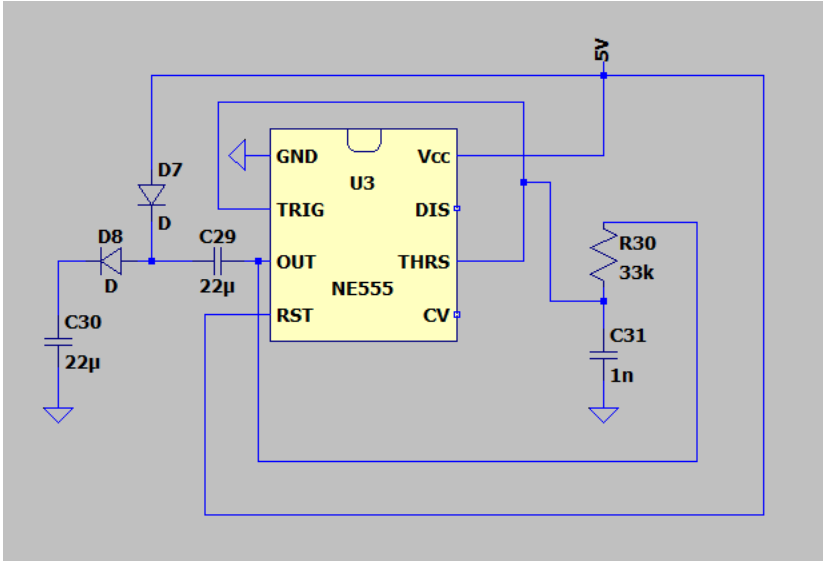

Figure 20: Voltage Doubler 2